

DAY 5 MONDAY, 27 JANUARY 2025

SHOWDAILY

The Daily News of IMTEX 2025

Organiser



Indian Machine Tool
Manufacturers' Association



International Machine Tool &
Manufacturing Technology Exhibition

Concurrent Shows



International Exhibition of Cutting Tools, Tooling Systems,
Machine Tool Accessories, Measuring & QC/CIM



International Exhibition on
Digital Manufacturing Technology

23 - 29 January 2025 : BIEC, Bengaluru



Scaling new heights
in manufacturing



Asia's Leading Fixture Builder



Winner of CII Industrial
Innovation Award 2020

Trusted By The World's Best Companies

For over 50 years Forms and Gears has been designing and manufacturing fixtures for the world's leading companies, in 10 countries across the globe.

RV Forms & Gears LLP

MF 11, SIDCO Industrial Estate, Guindy,
Chennai - 600 032, Tamilnadu, India
Call +91 77570 53326 or email us on
marketing@rvformsandgears.com

www.rvformsandgears.com





Asia's Leading Fixture Builder



Winner of CII Industrial Innovation Award 2020



Trusted By The World's Best Companies

For over 50 years Forms and Gears has been designing and manufacturing fixtures for the world's leading companies, in 10 countries across the globe.

RV Forms & Gears LLP
 MF 11, SIDCO Industrial Estate, Guindy,
 Chennai - 600 032, Tamilnadu, India
 Call +91 77570 53326 or email us on
 marketing@rvformsandgears.com
www.rvformsandgears.com



AUTOMATED SOLUTIONS FOR METAL CUTTING

MW80HGT

Twin Spindle Twin Gantry Chucker

MW120EX

Twin Spindle CNC Chucker

MT100/T3

Ultimate Multi-Tasking Twin Spindle Machine

MWR120

All New Twin Spindle Turn-Mill Centre with Y Axis

VISIT US AT

HALL 5 STALL B105

Bangalore | Chennai
Mumbai | New Delhi | Pune

CNC MACHINING SOLUTIONS

Dedicated to Driving Innovation

For Jyoti CNC Automation, participating in IMTEX 2025 is an opportunity to showcase its cutting-edge technological advancements and reinforce its position as a global leader in CNC machining solutions. The company uses this platform to emphasize its technological expertise and dedication to driving innovation, sustainability, and productivity gains for its global clientele.



Jyoti CNC is at the forefront of technological innovation, seamlessly integrating cutting-edge advancements like Artificial Intelligence (AI), the Internet of Things (IoT), and Industry 4.0 into its machining solutions. By harnessing AI-driven analytics, the company enhances precision, optimizes performance, and predicts maintenance requirements, ensuring minimal downtime and maximum productivity. IoT-enabled smart sensors provide real-time data monitoring, enabling remote diagnostics and adaptive control systems for unparalleled efficiency. Embracing the principles of Industry 4.0, Jyoti CNC delivers intelligent, interconnected, and automated machining ecosystems that empower manufacturers to achieve higher accuracy, scalability, and operational agility in today's dynamic industrial landscape. Through IoT-enabled devices, data-driven solutions for real-time monitoring and predictive maintenance, and smart manufacturing technologies, Jyoti CNC aims to accelerate the adoption of Industry 4.0. "We are also introducing eco-friendly machining techniques and energy-efficient

Himanshu Shaparia, President - Sales, Jyoti CNC Automation Ltd, acknowledges IMTEX as one of the most prominent machine tool shows that offers an ideal setting for showcasing the company's engineering prowess, introducing its most recent innovations, and establishing connections with partners, clients, and global industry leaders. "We, at Jyoti CNC, are committed to expanding the possibilities of automation and precise engineering. Our cutting-edge solutions featured at IMTEX 2025 meet the evolving needs of various industries, including the automotive,

aerospace, medical, and defence," he shares. "Our goal of international expansion and customer-focused growth is further demonstrated by our participation in IMTEX 2025. It gives us the opportunity to strengthen existing connections, explore new partnerships, and inspire confidence in our ability to deliver top-notch manufacturing solutions that can shape the future of the industry," he adds. **Highlights at IMTEX 25** To meet the evolving demands of contemporary machining, Jyoti CNC Automation Ltd is displaying

its comprehensive range of the state-of-the-art CNC machines and sophisticated machining solutions at IMTEX 2025. "As is our tradition, we are launching some of the finest and innovative machines at the Jyoti Pavilion (Hall 5). Our product line includes Turning and Turn Mill Centers, Vertical Machining Centers, Horizontal Machining Centers, 5-Axis machining Centers and Multi-tasking Machining Centers. Some of the high-precision machining centers are integrated with automation that offers accuracy and productivity," shares Shaparia.

To be continued on 4 ▶

Precision Machining.

Together.

Hall No-5 Booth No: A 129
quakerhoughton.com | info@quakerhoughton.com



Source: Magic Wand Media

» By displaying cutting-edge technology like AI-driven solutions and IoT-enabled machines, Jyoti CNC has not only proven its technical acumen but also reaffirmed its position in revolutionizing manufacturing in India and around the world. Jyoti CNC still relies heavily on IMTEX to propel innovation, broaden its customer base, and strengthen its reputation as a reliable leader in the CNC machining sector.«

Himanshu Shaparia
President - Sales
Jyoti CNC Automation Ltd

technologies with an emphasis on sustainable production. These developments enable enterprises to attain greater productivity, reduced downtime, and higher-quality production by aligning with the most recent trends in digital transformation and smart manufacturing," he adds.

IMTEX as a strategic platform for Jyoti CNC

Through IMTEX, Jyoti CNC has been able to interact with important stakeholders, including decision-makers, leaders in the industry, and prospective clients, forging solid alliances and relationships that have been essential to the expansion of the business. By strengthening its expertise in automation, digitization, and

smart manufacturing, IMTEX has also helped Jyoti CNC establish itself as a leader in the Indian machine tool industry. "By displaying cutting-edge technology like AI-driven solutions and IoT-enabled machines, Jyoti CNC has not only proven its technical acumen but also reaffirmed its position in revolutionizing manufacturing in India and around the world. Jyoti CNC still relies heavily on IMTEX to propel innovation, broaden its customer base, and strengthen its reputation as a reliable leader in the CNC machining sector," remarks Shaparia. **SD**

Jyoti CNC Automation Ltd
Hall & Stall: 5/A-122
www.jyoti.co.in

**UNLOCK
PRECISION IN
ELECTRONICS
MANUFACTURING
WITH ANCA CNC
MACHINES**



Download a free whitepaper on the latest trends, opportunities, and strategies shaping India's thriving electronics sector



Visit us at IMTEX 2025
Hall 4, Stand B110

IMTEX 2025 has garnered an overwhelming response, showcasing the immense interest and enthusiasm from industry professionals, students, and global participants. Over the first four days alone, the exhibition witnessed an unprecedented footfall of 84,000 visitors. This record-breaking attendance highlights IMTEX's role as a premier platform for innovation, collaboration, and technological advancements in the machine tool and manufacturing sectors. **SD**



Experience the Value in our Machines & Solutions

Hall - 5, Stall - A 108



- JD 2L** Compact Vertical Machining Center
- Stroke: (X,Y,Z) - 700 mm x 400 mm x 320 mm
 - Table Size - 850 x 400 mm
 - High speed Spindle - 12000 rpm
 - Spindle taper - BT 30
 - Pocket Tilting ATC with 21 tools
 - Rapid Traverse Rate - 48 m/min



JG50 R HIGH - SPEED MOVING COLUMN Vertical Machining Center

- Stroke: (X,Y,Z) - 480 mm x 400 mm x 400 mm
- Automatic pallet changer
- Pallet Size - 550 x 380 mm
- High speed Spindle - 12000 rpm
- Spindle taper - HSK A50
- Tool change time - 1 Sec
- Rapid Traverse Rate - 48 m/min



FOLLOW US ON :
f in x v @
LMW CNC



INDIA'S FINEST RANGE OF CNC MACHINES

TURNING MILLING TURNMILL



www.lmwncnc.com

IMTMA SUMMIT

Driving Manufacturing Excellence

Jointly organized by ACMA (Automotive Component Manufacturers Association of India) Mobility Foundation and Indian Machine Tool Manufacturers' Association (IMTMA), 'Auto Components Industry Transformation Summit' on January 26 at BIEC, during IMTEX 2025, promised to reshape the sector's future. The summit emerged as a beacon for industry leaders seeking to navigate the rapidly evolving landscape of auto components manufacturing.

Highlights of the Summit
Industry veteran Ganesh Mani, President & Chief Operating Officer, Ashok Leyland Ltd, delivered a keynote address on 'Machining Excellence in the Auto Components Manufacturing Industry'. Under the skilled moderation of Rajesh Nath, Managing Director, German Engineering Federation (VDMA) India Office, the summit featured a star-studded panel discussion on 'The Automotive Industry Driving India's Growth'.

The panelists included Dr Umesh Mhatre, Managing Director, Surface Modification Technologies Pvt Ltd; Dr Nagahanumaiah, Director, Central Manufacturing Technology Institute; Rohit Bhale, Director, Business Segment, Quaker Houghton; and B Thej Kumar, Vice President, Toyoda Gosei South India Pvt Ltd. A Fireside Chat with industry leaders on 'Analysis of India's Position in the Global Automotive Component Manufacturing Landscape' featured Sriram Viji, Managing Director, Brakes India Pvt Ltd and Chairman, ACMA Southern Region; Prashanth Doreswamy, President & CEO, Continental Automotive Components (India) Pvt Ltd; and Nath.

Working in Synergy

In his keynote address, Mani highlighted that the Indian automotive manufacturing industry is undergoing a significant transformation, driven by global trends. He emphasized the need for component redesign, with future components required to be lighter, tougher, and equipped with improved surface treatments to reduce friction. This shift, he noted, demands rapid innovation in production processes to align with evolving industrial requirements. Mani underscored the importance of a collaborative approach to enhance the quality of both products and production machinery, ensuring the creation of components that meet global standards at the most cost-effective rates. Echoing his sentiment, Nath said, "The Automotive, Auto Components and Machine Tool sectors have a synergy effect because the Auto Components sector is highly dependent on the Machine Tools sector. In fact, the Machine Tools sector is the backbone of the Manufacturing industry," Nath noted.

"With India's endeavor to become a US \$5 trillion economy and the Manufacturing industry to contribute about US\$1 trillion to it, the Machine Tools sector, I believe, will play a very important role in India's growth story," he added. Prashanth Doreswamy, President & CEO, Continental Automotive Components (India) Pvt Ltd, said "The Automotive sector contributes 7 percent to India's GDP and almost 49 percent to the Manufacturing GDP of India. In addition to that, it employs around 35 million people. "Fifty-five percent of the machines which Indian tool makers make is consumed by the Automotive and with and more factories getting automated, it is even more essential that we partner with IMTMA even more strongly to make our shopfloors with this digitized work much more efficient. For that, we are looking forward to have a close partnership with IMTMA and look forward to see and adopt many more innovations which could be used in our shopfloors."

Toward Growth

Viji added, "The Auto Components industry is the big contributor to the manufacturing segment of India – to both employment as well as the GDP of the country. The industry has experienced significant growth over the past several years. Today, it generates revenue exceeding ₹6.1 lakh crore and is also a significant contributor to exports from India. Over 25 percent of the total sales is in exports." "We hope that the Indian Machine Tools industry grow along with ACMA and work hand in hand to develop the next generation of solutions whether it be the next set of machine tools or automation or Industry 4.0 offerings for the industry," he further added.



Source: Magic Wand Media



Source: Magic Wand Media

Ministry of Heavy Industries, Govt. of India & Bureau of Indian Standards, Govt. of India "Machinery and Electrical Equipment Safety (Omnibus Technical Regulation) Order, 2024"

Mandatory "OTR Order 2024" Registration by Every Indian & Overseas Manufacturer of metal-cutting machines, accessories, aggregates, attachments and components of machine tools

NO sale permitted in India, without "OTR Order 2024" registration, from September 2025

MHI, BIS and IMTMA are Organising 'Awareness Session for Indian and Global Machine Tool Industry @ IMTEX 2025'

1500 - 1730 hours | Monday, 27 January 2025
'Jacaranda' Hall in "Conference Centre", BIEC (No Charges for Participation | MUST ATTEND)

Convert your HMC Machining to VMC Machining with Ease

Please visit us at

Stall No. **A102**,
Hall No. **H1A**

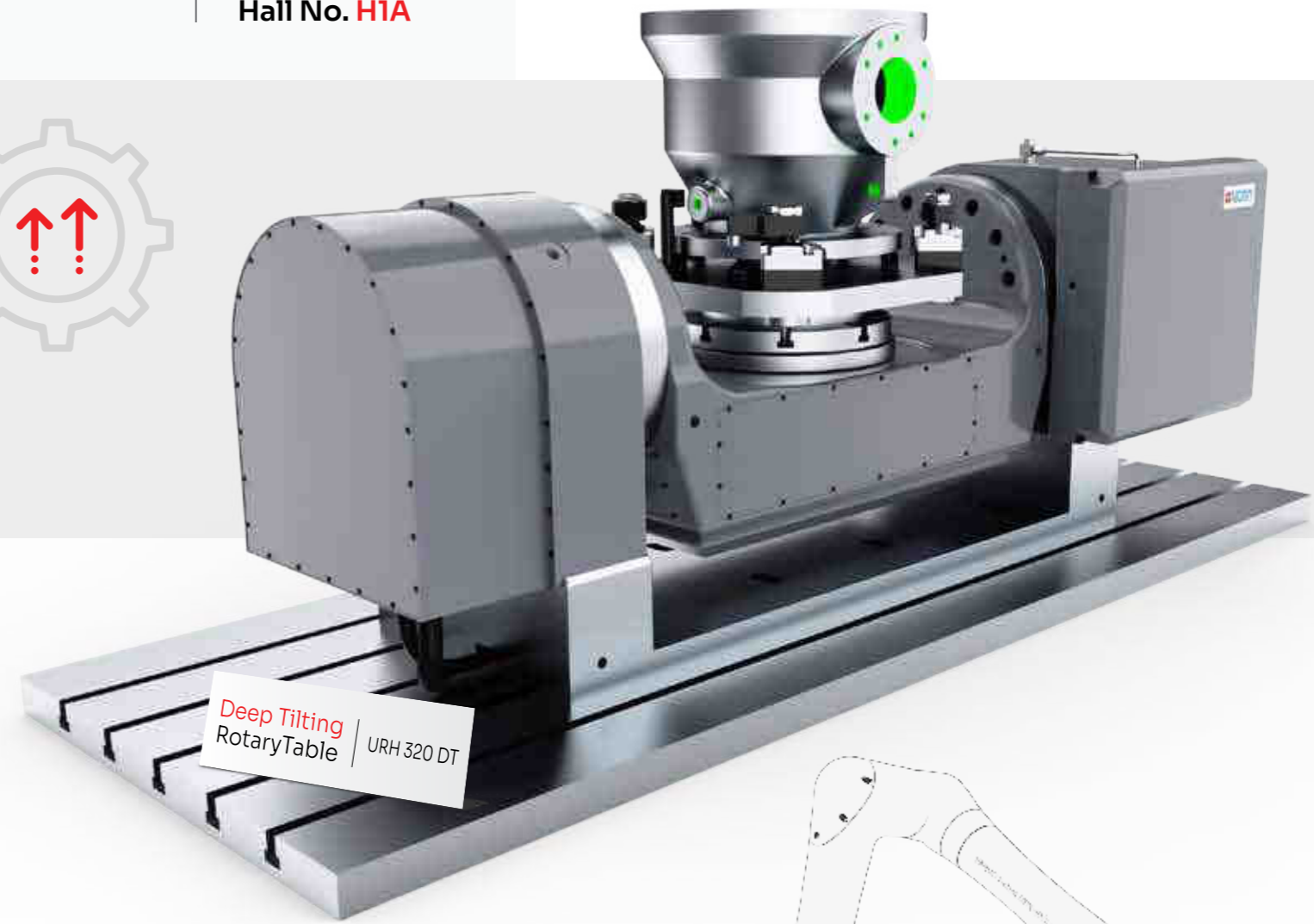

Introducing Advanced Automation & IOT Enhanced Rotary Tables



Scan this code or Log on to ucamind.com

Contact

080-40744712
info@ucamind.com
www.ucamind.com

Head Office

A-11/12, 1st Stage, 1st Cross,
Peenya Industrial Area,
Bangalore - 560058

MANUFACTURING TECHNOLOGY QUIZ CONTEST

Future Engineers Shine at IMTEX Quiz



1st Prize - KLS GOGTE Institute of Technology



Runner Up - Chennai Institute of Technology

Manufacturing Technology Quiz Contest, held at 'i2 Academia Square' in Hall 3C, Bangalore International Exhibition Centre (BIEC), during IMTEX 2025, demonstrated India's emerging manufacturing talent. The event brought together ten engineering colleges, with KLS Gogte Institute of Technology, Belagavi, clinching the top

spot and Chennai Institute of Technology finishing second. Rajendra Rajamane, President, Indian Machine Tool Manufacturers' Association (IMTMA), stressed, "The manufacturing sector is facing a talent shortage as young professionals gravitate towards white-collar careers, making these events crucial." He congratulated the participants and noted that the quiz is more

than just a competition. "It's a platform to spark interest and expose students to cutting-edge technologies," he said. Naveen G S, Director-Training, IMTMA, highlighted the quiz's broader impact and commended the management of engineering colleges for sending students to participate in industrial programs. "These interactions bridge the gap between the academia and industry, improve

their relationship, cultivate the essential industry-oriented skills, and pique the participants' interest in the engineering field," he said. The contest forms part of IMTEX 2025's comprehensive Academia Square program. By creating opportunities for students to demonstrate their technical skills, the event is helping them perceive manufacturing as a dynamic, innovative career path. **SD**



Rajamane & Hegde Services Pvt Ltd



Hybridspindle



More than only an alternative for indirect spindle solutions

The hybrid spindle is an impressive development - the combination of the master spindle motor and the spindle functionality results in a high-quality milling spindle.

The design includes all necessary spindle functionality, maximum speed up to 24,000 rpm and high accuracy because of direct driven technology. The Hybrid Spindle gives to machine builders the possibility to improve the performance of machines originally built with indirect spindle solution.

For more information, please ask for the spindle catalogue.

India's only authorised service partner for Weiss spindles

COMPLETE SOLUTIONS UNMATCHED PERFORMANCE



Step into a world of advanced engineering with STM's diverse product range, built to deliver superior quality and technological excellence across industries.

Crafted in **TAIWAN**,
Manufactured in **INDIA** | **3600+** Installations
Worldwide



Vertical Machining Center



VLVD Series

Double Column Machining Center



DL Series

APC Vertical Machining Center



VR Series

Horizontal Machining Center



HM Series

Graphite Machining Center



Graphite Series

5-Axis Machining Center



FX Series

Vertical Turning Lathe



VTL Series

CNC Cylindrical Grinding Machines



EGP & EGA Series

High Speed Machining Center (Drill Tap)



VD Series

S&T MACHINERY (P) LTD.

+91-422-2590810 | +91 99725 00090
info@stmcnc.com | www.stmcnc.com

DISCOVER THE MEANING OF VALUE



S&T GROUP
SINCE 1996



Visit Our Stall
HALL: 1A
STALL NO: B101

COOLANT PUMP SOLUTIONS

Pioneering Coolant Solutions



Rajamane Industries Pvt Ltd
www.rajamane.co
Hall & Stall: 3B/C-111

Rajamane Industries Pvt Ltd marks its 50th year of service to India's machine tool industry in 2025, a journey that began in 1975 with a single coolant pump model. "It's been a wonderful journey for us, and we are very thankful to the customers and vendors for their support," says V M Bellad, Executive Director, Rajamane Industries Pvt Ltd. From a single product line, the company now offers over 125 coolant pump varieties catering to machine tools, printing, packaging, filtration,

and chemicals. Collaborations with Germany's Brinkmann Pumpen in 1995 and Italy's Annovi Reverberi SPA in 2004 enabled Rajamane Industries to serve over 85 percent of the Indian machine tool market.

Launching New Products at IMTEX 2025

At IMTEX 2025, in addition to showcasing Oil Skimmers, RTH, and RFP All SS Series, Rajamane Industries has launched two new models designed to fill gaps in the market.

- **RSP Series:** A self-priming horizontal dirty liquid transfer pump, available in four models with capacities ranging from 100 to 800 LPM.
- **RXP Series:** An immersion-type vortex pump for chip transfer in filtration applications, available in four models ranging from 100 to 1,000 LPM.

"These two models are presently being imported from other countries for special applications in the machine tool industry," shares Bellad.

Quality and Global Standards

Rajamane Industries earned CE marking in 2003 and continues recertifications to ensure compliance with global standards. A backward integration initiative, including an in-house foundry and CNC shop, ensures quality and on-time delivery, achieving a 97 percent on-time delivery rate.

IMTEX: A Platform for Innovation and Growth

"IMTEX feels like a homecoming," Bellad reflects. "It provides exten-



Source: Magic Wand Media

» We want all our customers and vendors to be part of our 50-year celebration. The future market for all is going to be much bigger and we assure to be with them always.«

VM Bellad
Executive Director
Rajamane Industries Pvt Ltd

sive exposure and facilitates connections with both Indian and international customers, enabling us to expand our product range, drive innovation, and explore new market opportunities." The event offers Rajamane Industries an invaluable platform to showcase its commitment to innovation, quality, and customer satisfaction. **SD**

UNSTOPPABLE GRIT

NEED BETTER THROUGHPUT, PART QUALITY AND PRODUCTIVITY? TAP INTO UNITED GRINDING AUTOMATION SOLUTIONS.

Rising costs. Fierce competition. An ongoing labor shortage. In the face of all these obstacles, precision grinding operations are expected to stay profitable and productive.

It's a lot to ask, and it's too much to shoulder alone. Thankfully, UNITED GRINDING Automation Solutions were built to do that heavy lifting, day after day and night after night.

Hall 4,
Booth A 115



UNITED GRINDING AUTOMATION SOLUTIONS

- **ATP:** Automated Tool Production from WALTER
- **Tool changers:** fewer setups for better parts. Win-win.
- **Robot loaders:** instant tool grinding productivity boosters



PMT MACHINES LIMITED

PUNE & HALOL

CNC Turning Center 5000 ABC

CNC Gear Hobbing

CNC Vertical Turning

CNC Cylindrical Grinding

CNC Internal Grinding

Surface Grinding

Automat

YOU ARE INVITED TO VISIT THE EXHIBITION
HALL NO - 2A STALL NO - B110

23-29 January, 2025 | BIEC - Bangalore

www.pmtmachines.com

CLAMPING SOLUTIONS

Locking in Smarter Innovation

Andreas Maier Workholding Technology Pvt Ltd
www.amf.de | Hall & Stall: 4A/C-120



need tools that adapt quickly and work harder, and our ZPS innovations, including smaller modules, are designed with exactly that in mind," Mohan explains. Hydraulic clamping systems now feature 360-degree swiveling for greater flexibility in complex operations.

Industry Giants Trust AMF

"Key manufacturers like LMW, Makino, Phillips-Haas, Tsugami, Hurco, and even large fixture manufacturers like RV Forms & Gears have AMF products on their machines at IMTEX this year," shares Mohan. Visitors can witness live demonstrations simulating workplace conditions, in addition to displays and live presentations. These interactive displays provide a hands-on look at how Andreas Maier's innovations can optimize real-world manufacturing environments.

"We have always considered IMTEX as a pivotal platform to demonstrate our innovations in workholding technology to a diverse audience," says TV Mohan, Country Head & Managing Director - India,

Andreas Maier Workholding Technology Pvt Ltd. With over two decades at IMTEX and other IMTMA exhibitions, Andreas Maier focuses this year on smarter, adaptable manufacturing innovations.

Next-Gen Solutions

The big draw this year is the electric versions of Zero Point Systems (ZPS), along with new flange modules and compensation devices for large workpieces. "Manufacturers

"We've always been ahead of the curve when it comes to developing solutions like Zero Point Systems, which are used across industries like aerospace, automotive, and EV manufacturing," he adds. **SD**



Rajamane & Hegde Services Pvt Ltd



2SP2 Motorspindles



2SP2 the new middle-class standard

The new 2SP2 asynchronous milling spindle series is characterized by robustness and performance. Its compact dimensions meet the necessary requirements to keep the space requirement in the machine as low as possible. The option with or without external cooling jacket offers the machine builder flexibility in designing the connection of the spindle to the Z-slide.

Here, the new spindle series with an outer diameter of 170 mm already achieves a nominal torque of 45 Nm. For applications requiring more spindle torque, a variant with an outer diameter of 210 mm is available.

The spindle has been designed with a slim diameter and open cooling jacket but is also optionally available with a closed cooling jacket.

The robust bearing system ensures speeds of up to 20,000 rpm with lifetime grease lubrication. For speeds of up to 24,000 rpm, a version with air-oil lubricated bearings is also available. The specially developed asynchronous motor is equipped with loss-optimized profile rods to keep the rotor losses as low as possible. In this way, the spindle ensures low heat-up and reduced growth at the tool interface, even at maximum speeds.

For more information, please ask for spindle catalogue.

India's only authorised service partner for Weiss spindles

Visit us at Hall 3A, Stall B111

High Speed High Precision CNC Rotary Tables

4th Axis redefined

- Integrated angle sensor
- Positioning accuracy: ±5"
- High clamping torque
- Universal mounting

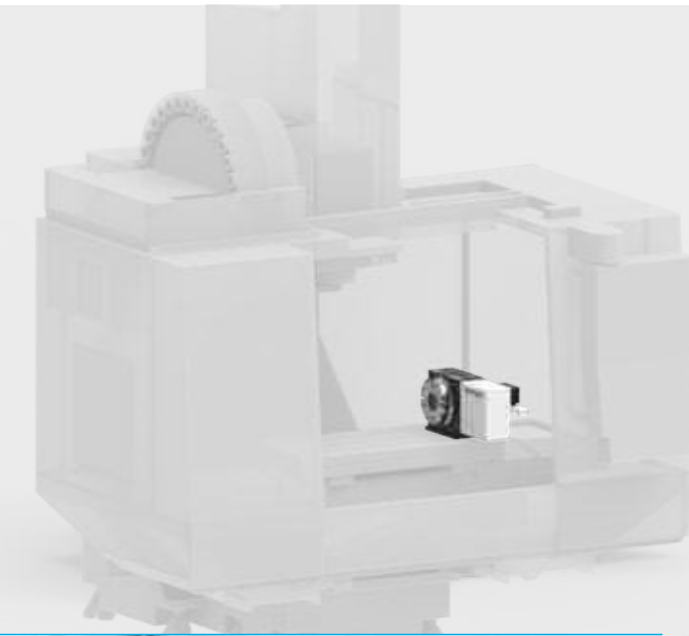

Your Partner For All Tool Holding Solutions

Up to fully automated tool change on lathes

- 1 QUICKLOCKBMT® tooling system
- 2 Tool holder HSK/SK/PSC
- 3 Automation for tool holder & work piece
- 4 Your work piece



Precision Gear Units

For all machine tools

- 1 Tool disk / magazine
- 2 Tool changer
- 3 Material handling solutions

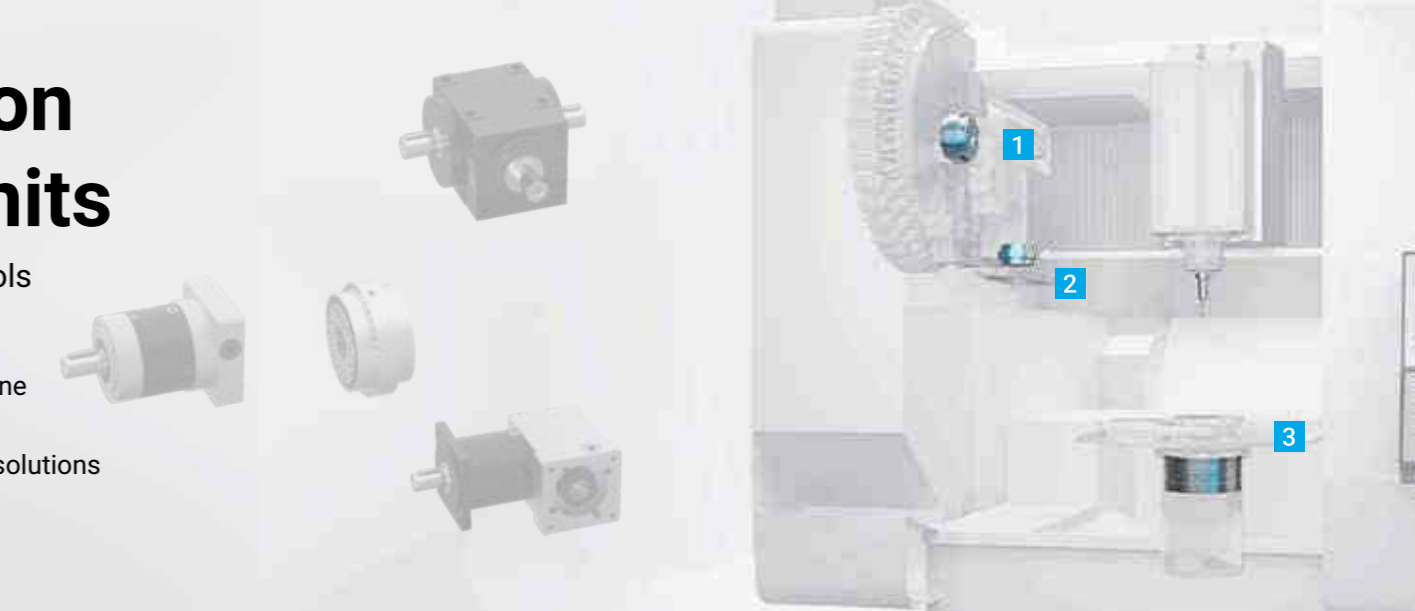

FOR SEMICONDUCTOR INDUSTRY



Horizontal Machining Center **HCN-6000**

A wide variety of spindles and high rigidity structure for efficient machining

- Spindle specifications to meet a wide variety of machining requirements
- The high rigidity bed is reinforced with strategically located ribs to ensure stability



5-axis Machining Center **VARIAXIS i-600**

5-axis machining centers with a wide variety of spindles and extensive automation equipment

- Multi-face machining and simultaneous 5-axis machining with one chucking
- Higher productivity with process integration



Yamazaki Mazak India Pvt. Ltd.
PUNE TECHNOLOGY CENTER
115, Pune Nagar Road, Sanaswadi, Pune. 412208.

www.mazak.com

Mazak

IN THE SPOTLIGHT

WIDMA Presents Innovative, High-Performance Machines At IMTEX 2025



Source: Magic Wand Media

WIDMA® Machining Solutions Group of Kennametal India Ltd, a leading manufacturer of metal cutting CNC machines, is showcasing a range of innovative machining solutions at IMTEX 2025, including the recently launched horizontal machining center, MachX800, and blank profile grinding solution, BPG 15. “We are thrilled to utilize the IMTEX platform to present our growing range of general-purpose and standard machining solutions for the Indian market. A key highlight of the event is our latest innovation, the MachX800, which reflects our

expertise in providing advanced solutions that guarantee exceptional quality and reliable performance. Additionally, customers can witness our extended range of next-generation solutions in action that are designed to meet their most challenging machining objectives,” said Vijaykrishnan Venkatesan, Managing Director, Kennametal India Ltd. The MachX800 Horizontal Machining Center (HMC) is designed for large parts machining across industries such as commercial vehicles, construction and farming equipment, aerospace

and general engineering. With IoT 4.0 integration, it provides the rigidity, efficiency, precision and flexibility required to work with diverse materials under challenging conditions.

Also in the Spotlight:

- **BPG-15 Blank Profile Grinding Machine:** This machine augments the Tool & Cutter Grinding machines portfolio, enabling customers to choose from a comprehensive range of solutions.
- **VT850 Vertical Turning Lathe (VTL):** This 2-axis, standard ‘plug-and-play’ VTL is designed

- for machining large components that require heavy metal removal.
- **VU1250 Multi-Tasking Turn-Mill Center:** This 5-axis turn-mill center integrates turning and milling functions in a single, rugged machine that lends itself readily to complex part geometries.
- **EcoGrind VX5 and SX5 LiMo:** These five-axes CNC tool and cutter-grinding machines are designed with premium features to deliver best-in-class productivity and versatility.
- **UGC Series Deep Hole Drilling Machine:** This series of machines combine the benefit of deep hole drilling with milling, drilling, and tapping operations in a single setup. **SD**

WIDMA
Kennametal India Ltd
www.kennametal.com
Hall & Stall: 1A/A-110

Inspiring Young Minds



Source: Magic Wand Media

The ongoing IMTEX has garnered significant attention of the student community, with many flocking to BIEC to explore the extensive range of machines on display and gain insight into the current industry trends. Manish, a first-year student and a first-time visitor was impressed by the wide variety of machines and the presence of renowned companies. He was particularly impressed with the comprehensive display of product offerings by Wigma company and was also fascinated by robotics offerings. The ‘i2 Academia’ initiative by IMTMA has been successful in attracting young talent from institutes to showcase their talents in the manufacturing space. Three first-year students Mohammad Affan, Mohd Awaiz and Mohd Abdul Yaseen from FBB Fathima IT College have showcased a CNC thermocol cutting machine which can cut any shape. **SD**



ZAVENIR DAUBERT

- Low Evaporation & Misting due to Superior Base Oil
- Higher Productivity due to Advanced Additive Technology
- Reduced Inventory costs due to wide application range
- Environment friendly EP Additives

Stall No. A112 | BIEC Bengaluru
Hall No. 3A | 23rd - 29th Jan, 2025

FOLLOW US ON www.zavenir.com



VIRAT 2030 PRO
DOUBLE COLUMN MACHINING CENTRE



WHN 130 CNC
TABLE TOP HORIZONTAL BORING MACHINE



ST 500X-2500 MTS
MULTITASKING TURNMILL CENTER



PL-5030L
HEAVY DUTY HORIZONTAL TURNING CENTER



BFW
Enabling Progress...

VISIT US AT
HALL-2A
STALL-A102

IMTEX 2025
International Machine Tool & Manufacturing Technology Exhibition



BVL 800ML
VERTICAL TURNING LATHE



BHTM 2070Y
HORIZONTAL TURNING LATHE WITH P-AXIS



ORION TH5500-50
HORIZONTAL MACHINING CENTRE



XTRON 744+
VERTICAL MACHINING CENTRE



OMEGA 3060
VERT. SPEED SPINDLE MACHINING CENTRE



5X-B600
5-AXIS MACHINE



OMEGA PENTA 305
CONTRAVALVE-5-AXIS MACHINE



PHOMEX-H
HYBRID MACHINE



OMEGA DUO 30
TOP-SINGLE MACHINING CENTRE

+91 93423 36169 | bfwmarketing@bfw.co.in | www.bfwindia.com | Off Tumkur Road, Bangalore - 560022

SPECIAL PURPOSE MACHINES

Taurus Riser Cutting Machine – TRCM-22

Taurus Riser Cutting machine TRCM-22 is suitable for the cutting of 'Riser and Runners' on aluminum alloy castings for automobile alloy wheels. The machine is designed to take alloy wheels from 10 in to 22 in diameter. This machine has an intelligent system equipped with uniquely developed software and hardware, incorporating features that entirely 'de-skill' the operation process. A high-resolution camera at the input chute captures the image of the incoming component and loads it into one of the four stations within the machine. The system then automatically configures all necessary settings, including the clamping mechanism, appropriate CNC program, axes travel, and cutting parameters. The next component to be loaded at the subsequent station can have entirely different dimensions (diameter and height). The machine accurately recognizes this new component and adjusts its settings instantly and automatically. This



Taurus Pvt Ltd
www.taurusspm.com | www.acemicromatic.net
Hall & Stall: 5/C-124

eliminates the need for a skilled operator to be present at all times to run the machine. Also, this machine's intelligent system facilitates Single Piece flow instead of normal Batch manufacturing. The machine is of an integral design and is highly compact. All elements are machine mounted including all electrical items. The electrical panel

and the operator panel are machine mounted and ergonomically accessible. This design allows the machine to be easily moved from one place to another. Also, electrical control panels are also compact and fitted with AC panel coolers / heat exchangers. Due to this, the machine need not have separate AC room for its control panel.

The machine has a rigid base that is optimized using FEMA analysis. It has a four-station rotary mechanism. Each station is equipped with a pneumatically operated self-centering three-jaw chuck. The jaws automatically clamp the component based on the input size. All operations in the machine are controlled by a CNC System (FANUC) and high-torque Axes Servo Drives (FANUC) with absolute encoders. Component loading and unloading is with a custom-made automation system. The machine bed is designed for a better chip disposal and a heavy-duty chip conveyor is optional. The machine features a centralized auto lubrication system and a mist coolant system for cutters. It is designed with adequate ground clearance to facilitate easy maintenance. The machine guards are not only intended for safety but are also designed to be maintenance friendly.

DELEGATE SPEAK "IMTEX 2025 Has Been Excellently Organized"

IMTEX 2025 is a remarkable exhibition featuring cutting-edge machine tools integrated with the latest technologies. It's truly inspiring to see students from various engineering colleges presenting their innovative projects and taking interest in the manufacturing industry. This will lead us to attain the global manufacturing standard. IMTEX 2025 has been excellently organized. I have been told that this year's edition has witnessed the highest turnout so far. IMTMA's systematic management ensures visitors can conveniently explore the displayed machines. I deeply appreciate IMTMA's efforts in successfully conducting this large-scale event.

Dr S Selvakumar
Principal Secretary
Commerce & Industries
Government of Karnataka



Source: Magic Wand Media

Would you like to be crowned a Productivity Champion ?
.... Share your success stories on PRODUCTIVITY | TECHNOLOGY | INNOVATION

Win Cash Awards upto
₹ 10,00,000

AWARDS SPONSOR
AceMicromatic Group

@
National Productivity Summit 2025
November 2025, Ahmedabad

No Entry Fee ! Multiple Entries are Welcome ! Rush your entries by 5 April 2025

Special streams Micro and Small Enterprises | Non-Automotive Industry | Automotive and Auto Component Industry

For more details, please log on to: www.productivity.imtma.in
or call Madan on: +91 7899437625 | E: madan@imtma.in

Organised by: Indian Machine Tool Manufacturers' Association
www.imtma.in

PALMARY GROUP

For Sale

CENTERLESS



CYLINDRICAL



VERTICAL



SPECIAL FEATURES

- Compound Grinding Solutions
- High Precision and Quality
- Seamless Automation
- Eco-friendly Design
- User-friendly with Intuitive Graphic Interface

Call for details
+886-4-24929799

For More Information
palmmary@grinding.com.tw

Visit Us
www.palmmary.com



WORKHOLDING SOLUTIONS

Showcasing Innovation and Leadership



» IMTEX is a place where the industry meets. Other than connecting with old clients, we hope to meet potential clients too.«

Reji Varghese
President
RV Forms and Gears

RV Forms and Gears, a pioneering name in workholding solutions, is all set to make a significant impact at IMTEX 2025. With over five decades of expertise in fixture building, the company's participation underscores its commitment to technological advancement and its robust presence in the global manufacturing market. Reji Varghese, President, RV Forms and Gears, acknowledges IMTEX as a crucial platform for the industry and is keen to connect with the company's existing and potential Indian and foreign customers during the exhibition. The company is displaying a fixture enabled with IoT and AI/ML along with a few other fixtures. This technology has been hailed by the industry fraternity, making RV Forms and

Gears earn the prestigious CII Innovation Award. **Evolution of Manufacturing Sector** As one of India's oldest fixture-building companies, RV Forms and Gears has witnessed a remarkable transformation in the manufacturing sector over its 53-year journey. "The market has undergone significant transformations over the last five decades, driven by advancements in automation, robotics, and Industry 4.0 technologies. The Asia-Pacific region, particularly India and China, has emerged as a major hub for manufacturing," says Varghese. **Workholding Fixtures Enable Precision Machining** Varghese highlights that companies do not realize the pivotal role

fixtures play in unlocking the potential of CNC machining centers and cutting tools. "They compromise on fixtures thinking they are saving cost but in reality they pay a heavy price for it," he notes. "Our fixtures are designed to withstand the high cutting parameters modern day CNC machines use while enhancing quality and repeatability. Automatically adjusting work supports become rigid supports during machining and prevent deflection and vibration during the machining cycle," he shares. Additionally, RV Forms and Gears' hydraulic clamping systems significantly enhance efficiency in high-volume production environments. Varghese explains, "Our hydraulic fixtures allow for much faster machining cycles. Power clamps offer added security

as they are not only independent of operator intervention, but also offer consistent and high clamping forces. Holding forces can also be adjusted to suit the specific requirements of the component." The use of work supports enables higher cutting parameters to be used, translating into lower cycle times. "Work supports can be introduced into unsupported and inaccessible areas which greatly improve the rigidity of the fixtures during high-speed machining, markedly improving quality parameters too," he adds. **SD**

RV Forms and Gears
www.rvformsandgears.com
Hall & Stall: 7/B-112

PROCESS FLUIDS

Accelerating Manufacturing with Quaker Houghton

As the transportation industry evolves, the demand for lighter-weight, cleaner-running and more efficient vehicles continues to rise. "Our formula for success is continuous improvement through innovation. We constantly refine our offerings to provide market-leading process fluids, Industry 4.0 technology for fluid optimization and solutions that ease the transition to e-Mobility manufacturing," says Rohit Bhale, Director, Business Segment, Quaker Houghton. For Internal Combustion Engines (ICE), efforts are focused on

enhancing the quality, productivity, and cost-efficiency of the entire manufacturing process. Quaker Houghton's solutions for ICE cover all aspects – from die casting and machining to coatings. In the realm of e-Mobility, manufacturers are encouraged to tackle challenges with confidence and accelerate their progress toward electrification. This is made possible with Quaker Houghton's expert support and its full suite of solutions designed for structural die casting, e-motors, and battery components.

Progressing with Quaker Houghton

The future of mobility is fully electric. And the journey has already begun. To stay ahead, one needs fluid solutions for a whole new set of manufacturing challenges. With Quaker Houghton, one can get access to a comprehensive range of cutting-edge products, Industry 4.0-ready technologies, and the support of top application experts to accelerate one's journey to an electrified success. Whether one is working with Battery Electric Vehicles (BEVs), Hybrid Electric Vehicles (HEVs), Plug-in Hybrid Vehicles (PHEVs) or Fuel Cell Electric Vehicles (FCEVs), they can count on the global leader in the industry to help them propel ahead.

"Continuous improvement is at the core of what we do. Whether we are refining our formulas, enhancing our technology, or optimizing our customers' performance, we are always committed to innovation that moves e-mobility forward. That's why we are the partner of choice for driving more



» Our formula for success is continuous improvement through innovation. We constantly refine our offerings to provide market-leading process fluids, Industry 4.0 technology for fluid optimization and solutions that ease the transition to e-Mobility manufacturing.«

Rohit Bhale
Director
Business Segment
Quaker Houghton



Source: Quaker Houghton

productivity, cost-efficiency and quality in EV manufacturing processes," states Bhale. **SD**

Quaker Houghton India
www.quakerhoughton.com
Hall & Stall: 5/A-129

HORIZONTAL MACHINING CENTERS

HP Series from Jyoti CNC

The high-performance HP Series from Jyoti CNC is the cutting-edge evolution of horizontal machining centers, crafted with the foundational elements of rigidity, accuracy, and high dynamics. This extraordinary series is designed for peak performance, with an exciting potential to boost productivity and

deliver exceptional reliability, guaranteeing top-notch machining outcomes. Equipped with state-of-the-art technology and precision engineering, the HP Series sets an innovative standard for efficiency, paving the way for the future of precision manufacturing. Built on a robust, heavy-duty bed made from high-quality graded cast iron and other resilient materials, this series showcases a unique Step Up Structure that enhances load distribution. The wide T-base structure ensures outstanding stability, enabling vibration-free cutting for larger job envelopes along the X-axis, even in extreme positions without any overhanging effects—ensuring superior cutting capabilities. Packed with intelligent features, the HP Series boasts a servo-driven Digital Door for the ATC that synchronizes with tool length, significantly reducing chip-to-chip change time while preventing unwanted coolant or chip entry. With Jyoti electro spindles featuring HSK 100 and BBT 50 tapers, this series delivers impressive power, torque, and RPM. **SD**



Source: Jyoti CNC Automation Ltd

Jyoti CNC Automation Ltd
www.jyoti.co.in
Hall & Stall: 5/A-122

COLLABORATION

Laser Technologies and Manleo Designs Join Forces



Source: Magic Wand Media

Rakesh Aggarwal's Laser Technologies Pvt Ltd and Manleo Designs, India's only CNC precision probe and tool setter manufacturer, have formed a joint venture. This partnership unites technology and business expertise, combining innovation with dynamic leadership. Together, they aim to revolutionize precision engineering, strengthening India's position in the global CNC tooling industry. **SD**

Manleo Designs Pvt Ltd
www.manleo.com | Hall & Stall: 6/B-102

TUMAKURU MACHINE TOOL PARK

ATTRACTIVELY PRICED READY TO BUILD INDUSTRIAL PLOTS
VASANTHANARASAPURA INDUSTRIAL AREA - PHASE III

Machine Tools
All types

Parts Accessories
attachments,
Sub-Systems

Cutting Tools
Tooling

Dies &
Moulds

Electrical &
Electronics I4.0

Automation

Service
Providers

INDUSTRIAL PLOTS | LOGISTICS | SOPHISTICATED AMENITIES | COMMON FACILITIES

For queries please contact Mr. Manjunath.L Chief Marketing Officer, TMTP.
Ph: +91 9845525245 Email: cmo@tmtp.in

Government of India
Ministry of
Heavy Industries

Government of Karnataka
Karnataka Industrial Area
Development Board (KIADB)

Tumakuru Machine Tool
Park (TMTP)

www.tmtp.in

INTERNATIONAL PRESENCE - AMT

Exploring India's Manufacturing Potential

According to Doug Woods, President, AMT – The Association For Manufacturing Technology, IMTEX 2025 & Tooltech 2025 will build upon the success of the manufacturing technology events held in 2024. “These events have highlighted a strong interest in exploring the latest advancements in manufacturing solutions, while also providing a platform for networking with industry leaders and peers,” he notes.

Upping the Manufacturing Game

When asked about the trends in metal cutting technology, he replies, “Starting with the tooling, we see continued acceleration and integration of advanced materials like CBN, PCD and ceramics which provide superior hardness and wear resistance

allowing for higher cutting speeds and improved surface finishes and accuracies.” At the machine level, he points out numerous trends improving performance such as integrated automation, in situ sensor and metrology systems, enhanced UI/UX HMIs, optimized power usage features, and embedded AI provided real-time analytics.

US Companies' Partaking in IMTEX 2025

“There are more than 40 AMT Member companies participating in the show and we have about a dozen AMT members exhibiting in our AMT USA Pavilion located in Hall 1B,” Woods shares. Most other members are exhibiting on their own through their Indian subsidiary and still others with their agents or distributors.

Sharing the tune of exports having taken place from US to India in 2023-2024 and imports from India to US in the Machine Tool sector, he reveals that according to Trade Data Monitor (TDM), the source AMT uses for global trade data, during the period from January 2022 to September 2024, India imported US\$ 254 million worth of machine tools from the US. During this same period, India exported US\$ 80 million to the US. “India consumes about US\$ 3 billion of machine tools every year and over 60 percent of this is imported. With the US accounting for less than 10 percent of the imported manufacturing technology, there is plenty of room for American producers to expand and capitalize on the opportunities within the booming Manufacturing sector in India,” he concludes. **SD**



Source: AMT

» With a population of nearly 1.4 billion, the Indian market presents vast potential, attracting investors eager to expand their presence in India and collaborate with innovative Indian manufacturing technology companies to drive business growth on a global scale.«

Doug Woods
President

AMT – The Association For Manufacturing Technology

AMT – The Association For Manufacturing Technology
www.amtonline.org
Hall & Stall: 1B/B-104A

reCool® System



Booth #B108
Hall 3A

Upgrade your lathe to coolant through without losing machining range

www.rego-fix.com



DRIVE
THE FUTURE OF
MANUFACTURING
TECHNOLOGY!



Concurrent Shows



8 - 11 May 2025, Bharat Mandapam (Pragati Maidan), New Delhi

BOOK YOUR STALL NOW



Indian Machine Tool
Manufacturers' Association

Powered by IMTMA, organizer of **IMTEX**



www.mtx.co.in

www.facteq.in

**PROPELLING TECHNOLOGY.
PROSPERING LIFE.**



AEROSPACE



jyoti.co.in/huron.fr

DEMONSTRATING **LIVE**

Hall 5

at Jyoti Pavilion

Widest Range of CNC Machines

- | Turning / Turn-Mill Centers
- | Vertical Machining Centers
- | Horizontal Machining Centers
- | 5-Axis Machining Centers
- | Multi-Tasking Machining Centers

